

12 Modifying Parameters Contours

Primitives that contain a contour (prism, revolution, sweep, pyramid or pipe) may be modified by selecting a new contour or modifying the existing contour. (The original contour cannot include any interior domains; see [“Replacing the Base Solid” on page 258.](#))

In this example, we are going to modify our prism contour to include the quarter circle. We retrieved the parent lines from NO SHOW and created a quarter circle to be included in the new contour.

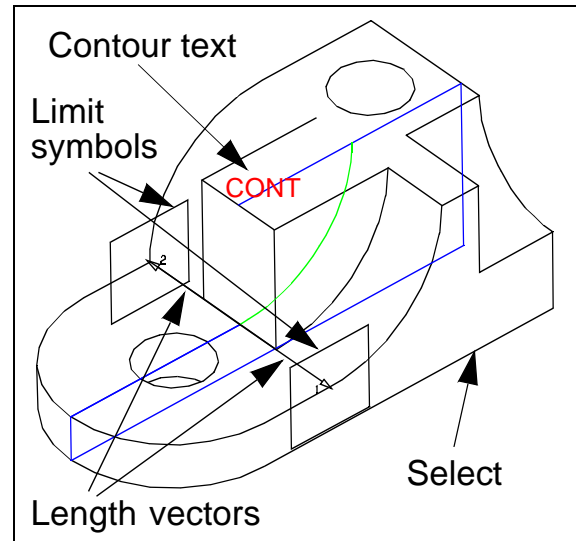

SOLIDE +MODIFY+GEOMETRY+PARM

```
{ SEL PRIM }
```

Select the solid primitive either directly or from the CSG tree.

[PRIMITIVE WITH EDITABLE PARENTS]

```
{ SEL SYMB }
```

```
{ DIR: SEL LN/PLN // YES:MODIFY }
```

The extrusion direction can be changed by selecting a line or a plane (normal to the plane). A new length can be keyed in, if the length vectors are selected. (These lengths can also be changed in the prism panel.) The limit planes could be selected and new planes applied. But for this example, we are more interested in selecting the CONT text that is used for selecting a new contour.

Select the CONT symbol.

```
{ NEW CONTOUR: SEL LN/CONIC/CRV/CCV }
```

```
{ CONTOUR: SEL PT/FAC }
```

If the original contour is a CCV, you can only select (define) a completely new contour. (Elements belonging to a CCV cannot be individually selected; see [“Modifying the Contour of a Solid” on page 252.](#)) If it isn't a CCV you can use, but not modify, existing elements in the new contour.

Select the green quarter circle.

```
{ CONTOUR: MSELW LN/CONIC/CRV/CCV }  
{ CONTOUR: SEL PT // YES:END }
```

The system automatically searches for joined single-parameter elements that can be added to the first element to form a closed contour. If there are multiple solutions, you must manually select the desired path.

You can also select points (in the plane of the contour) to create temporary line segments. To close this contour we could either select one of the end points, or hit **YES** to have it automatically closed by a temporary line segment.

Hit **YES**.

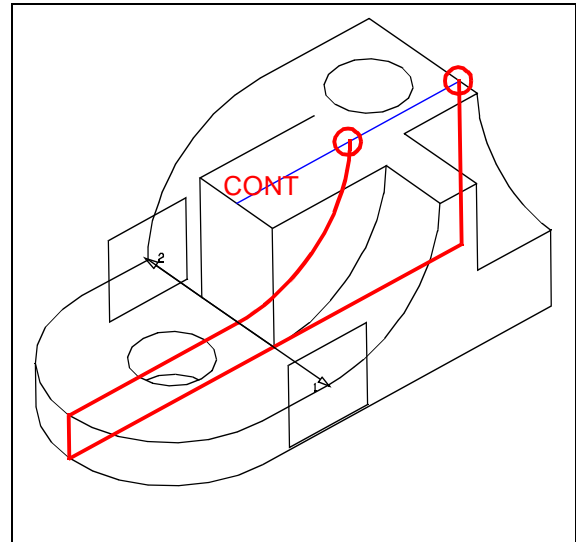

[LINE CREATED TO CLOSE CONTOUR]

```
{ SEL SYMB }  
{ DIR: SEL LN/PLN // YES:MODIFY }  
Hit YES.
```

[PRIMITIVE MODIFIED]

The solid has to be updated to take these changes into account.

If you take a look at your CSG tree, you can see that changing this contour made a few primitives into "ghosts", as they no longer contribute to the solid.

The tree should now be cleaned up and the nub and additional quarter section could be added. In fact by planning ahead, we could have used some of the former geometry to create the new additions, prior to modifying the contour.

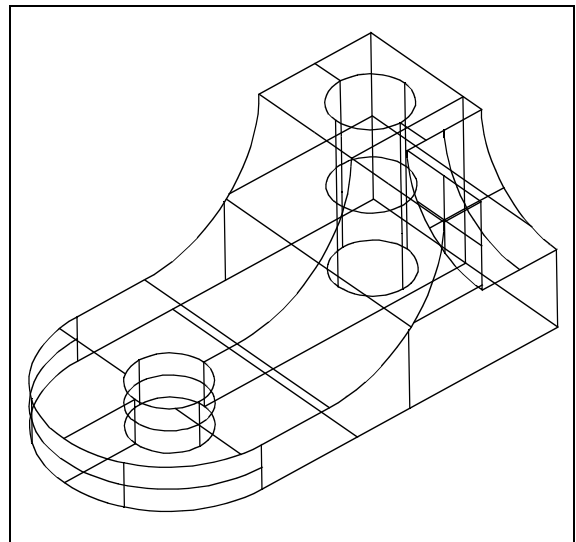

13 Modifying Contours (temporary parametrics)

The CONTOUR option is used to apply "temporary" parametrics to any solid primitive that was created using a contour (prisms, solids of revolutions, sweeps, pyramids and closed pipes).

For those of you familiar with the PARAM3D function, the temporary parametrics used in modifying solids will be very easy to understand. If you don't have a background that includes parametric modeling, this will serve as a good introduction.

Let's work our way through a simple example to see the technique for applying temporary parametrics. We're going to use the contour of the Rotor as our first example.

Note: If you are working with a solid detail, you must first switch into the detail workspace of the contour. When working with parametrics, you need access to the parent contour curves. They can be in NO SHOW mode, but only if they are in the current workspace.

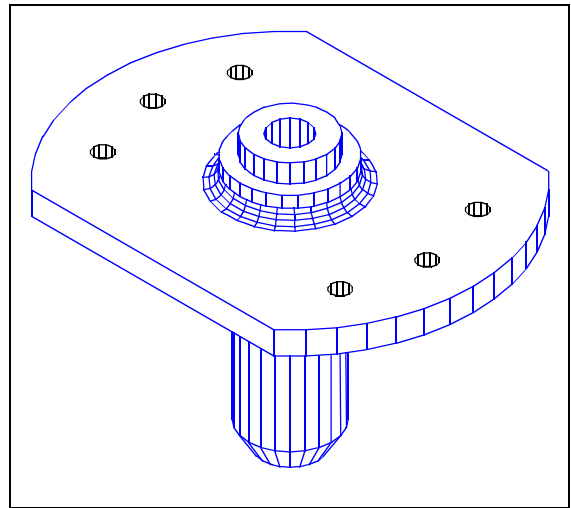

SOLIDE +MODIFY+GEOMETRY+CONTOUR

```
{ SEL PRIM }
```

Select the rotor primitive.

All elements that are not on the plane of the contour are switched to non-selectable mode. All elements that lie on the contour plane are displayed (even if they are currently in NO SHOW). The contour is displayed in highlighted mode (it also was in NO SHOW.)

```
{ MSEL PT/LN/CONIC/  
CRV/CCV }
```

```
{ YES:END }
```

Select the elements you wish to use in parametrizing the contour. In this case, select the center line.

